

Control unit CU-200 (US)
 Swing Door Operator
 Connection drawing

ASSA ABLOY
 6.0 1007329-en-US

EXU-SI

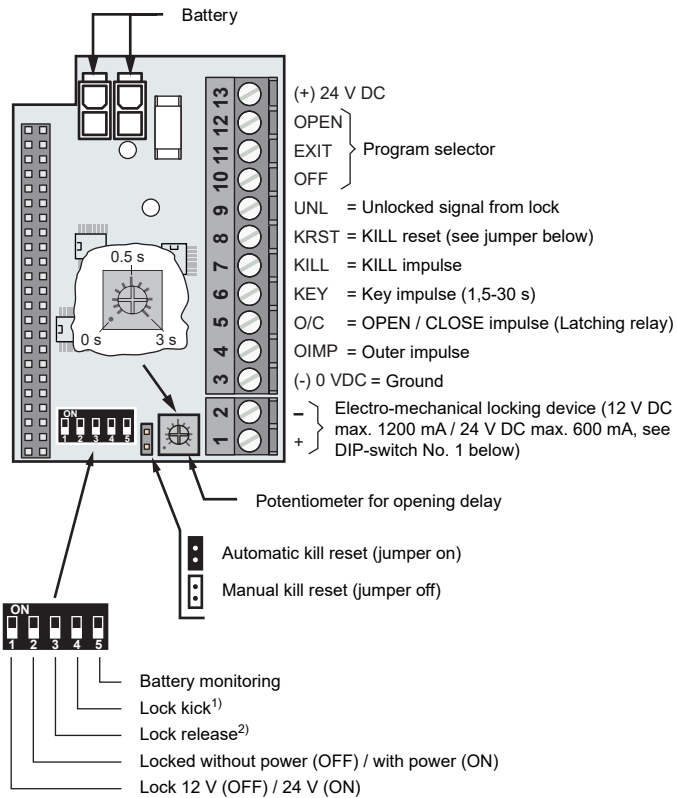

¹⁾ Independent of switch position (ON / OFF), the "latch check" complies with the ANSI 156.19 requirements.

Position OFF: Smooth closing, to be used on doors without lock.

Position ON: More powerful closing, to be used on doors with lock, to overcome binding in the locking device.

²⁾ If the switch is set to ON, the LOCK RELEASE is active during the opening delay time set by the potentiometer.

For "PAIR OF DOORS" installations, the "LOCK RELEASE" works in sequence: First the primary then the secondary.

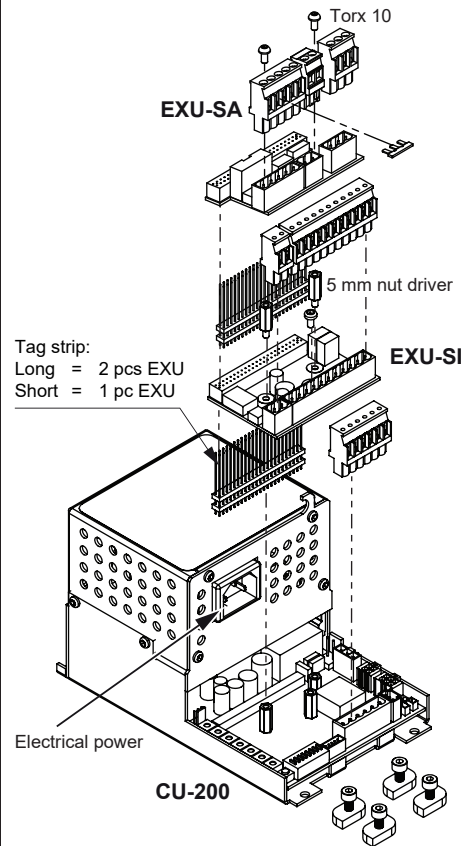

EXU-SA

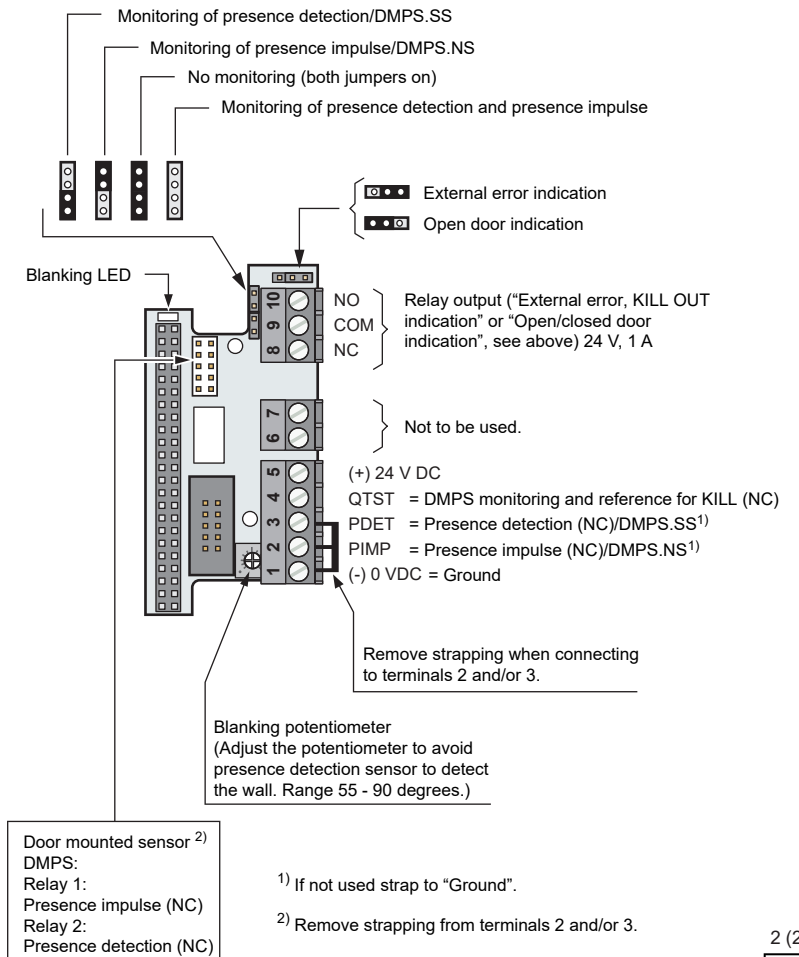

Accessories

EXU-SI
 EXU-SA