

General dimensions

Installation dimensions and how to use see next sheets.

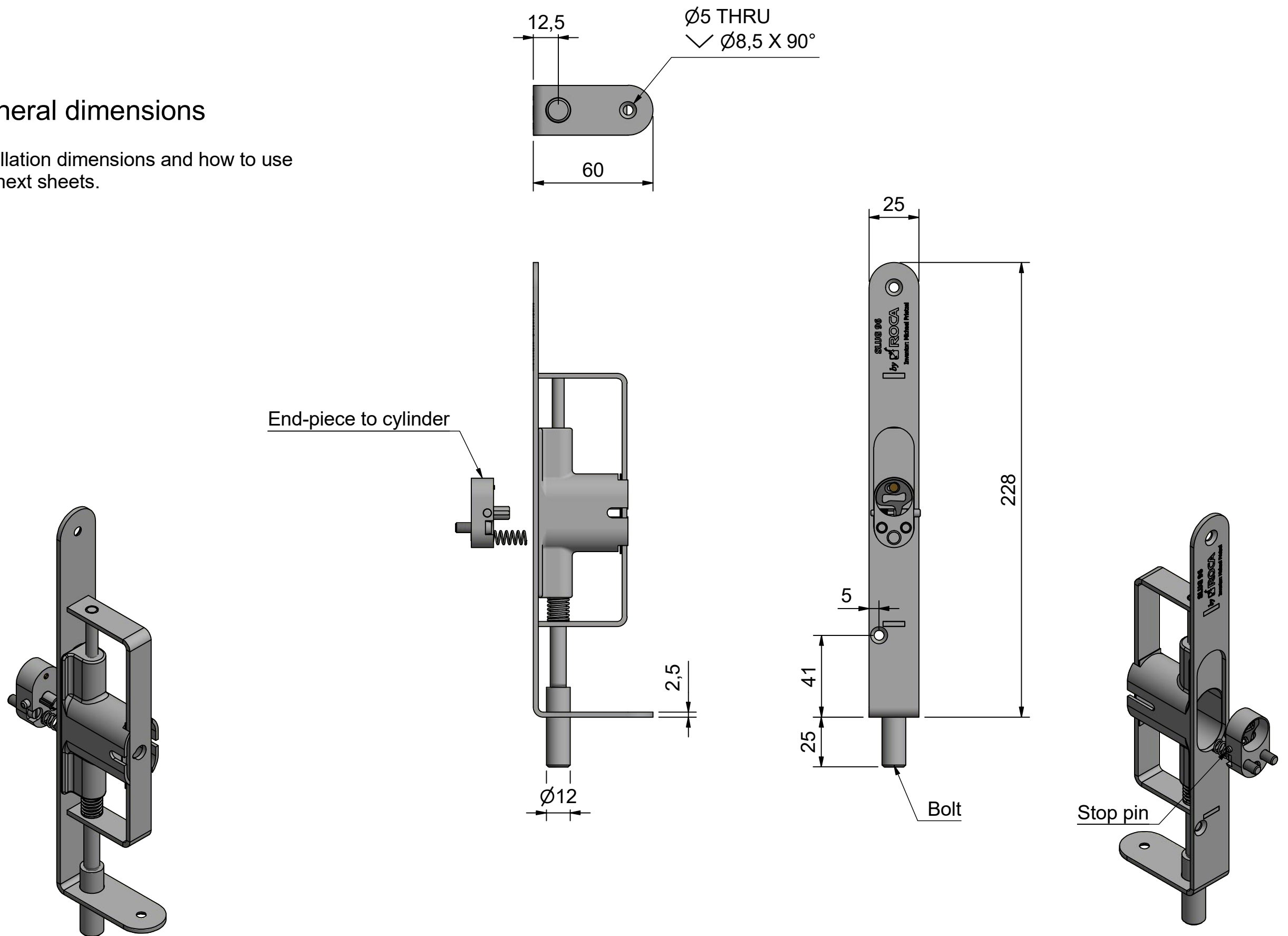

Recessed mounting (massive doors)

How to install and use.

1. Use the enclosed wood screws to attach the lever bolt to the door.
2. Connect cylinder with the end-piece
3. Puch down the fully assembled push button cylinder by turning the key clock wise while pushing the stop pin. Make sure in correct position.
4. Lock by sliding the cylinder until it can't be further moved. Then push in cylinder until it locks.
5. Unlock by turning key clock-wise until cylinder pops out.
6. Cylinder can be changed in the unlocked state if you simultaneously push in the stop pin and pull out the entire cylinder package.

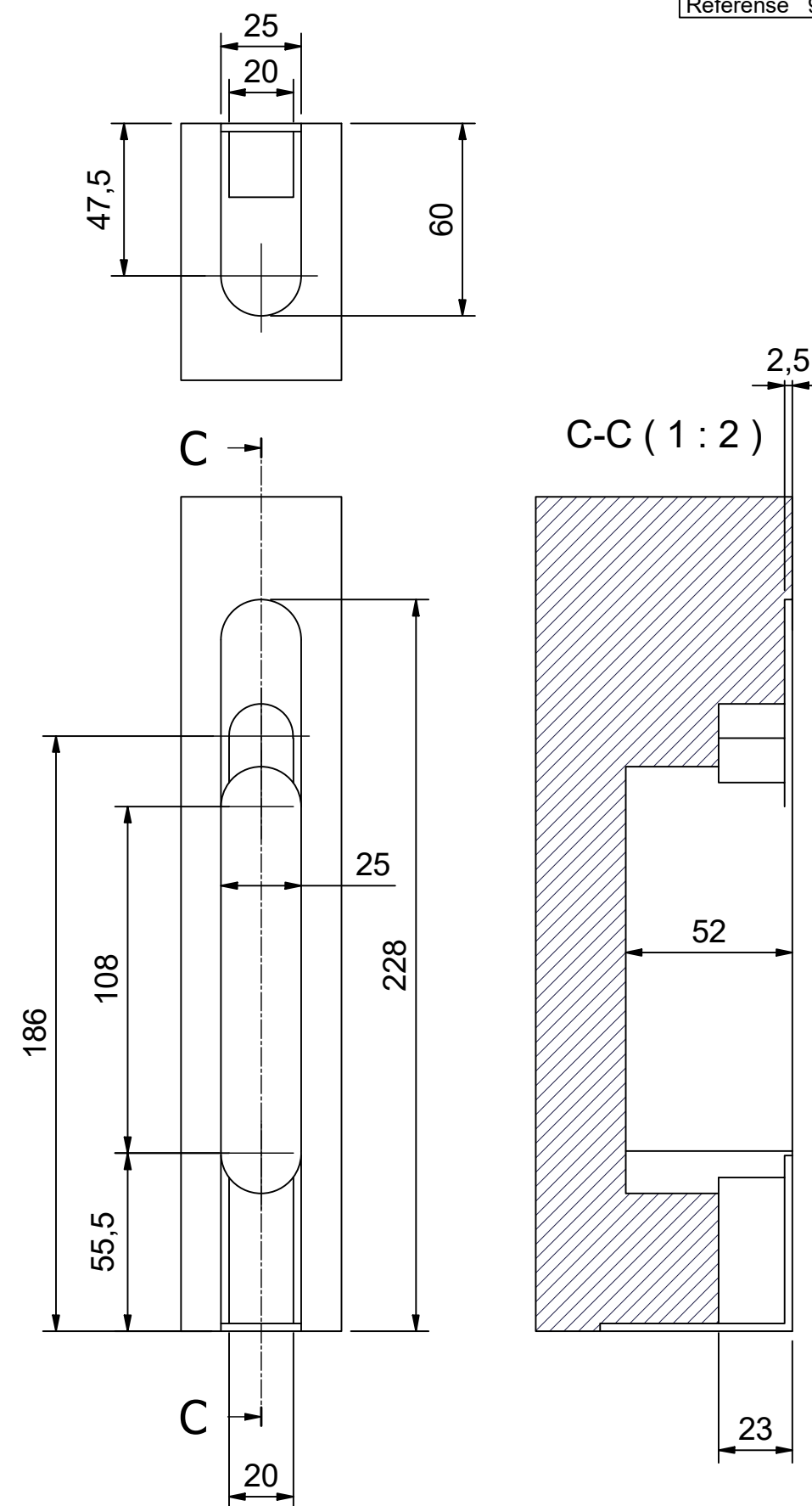
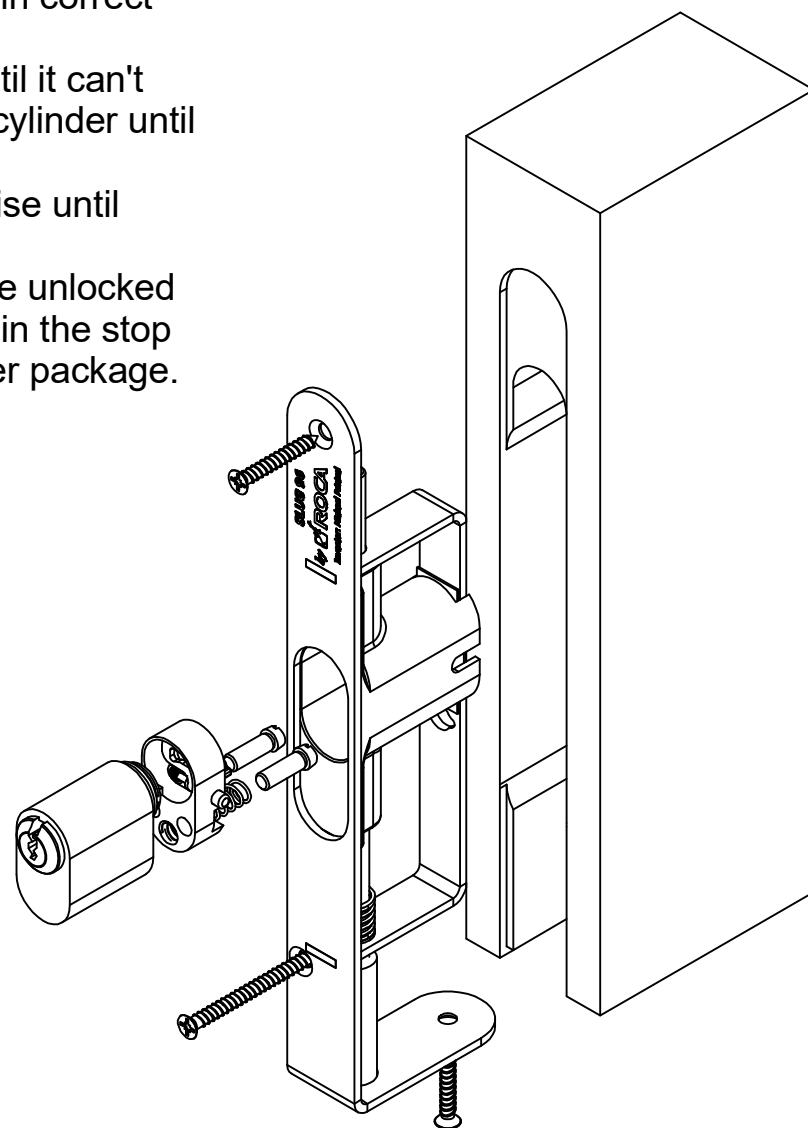

ROCA

Surface mounting (sheet metal doors)

How to install and use.

1. Slide the cylinder housing until the bolt reaches its maximum protrusion (1.1). Keep it in this position while the lever bolt is applied to the door (1.2). Use the enclosed sheet metal screws to attach the lever bolt to the door.
2. Connect cylinder with the end-piece
3. Puch down the fully assembled push button cylinder by turning the key clock-wise while pushing the stop pin. Make sure in correct position.
4. Lock by sliding the cylinder until it can't be further moved. Then push in cylinder until it locks.
5. Unlock by turning key clock-wise until cylinder pops out.
6. Cylinder can be changed in the unlocked state if you simultaneously push in the stop pin and pull out the entire cylinder package.

